

# BSA SERVICE SHEET No. 812

Reprinted Nov. 1958

## Model D.1

### LUCAS ALTERNATING EQUIPMENT

#### Alternator Model 1 A 45

#### DESCRIPTION

##### Inductor Type Alternator

The Lucas Model 1A45 unit, which has a nominal output of 45 watts, makes use of a generator of the inductor type. The consists of a 6-pole laminated steel rotor and a stator, the latter comprising two permanent magnets, a laminated field system and two coil windings housed in an aluminium casing. The rotor, with which is combined the contact breaker Cam, is bolted direct to the engine crankshaft. The Alternator body, which carries the Stator Coils and Contact Breaker Plate, is spigotted into the Crankcase. The Contact-breaker Plate is located by two fixing Screws passing through radial slots, Fig. Y.41.

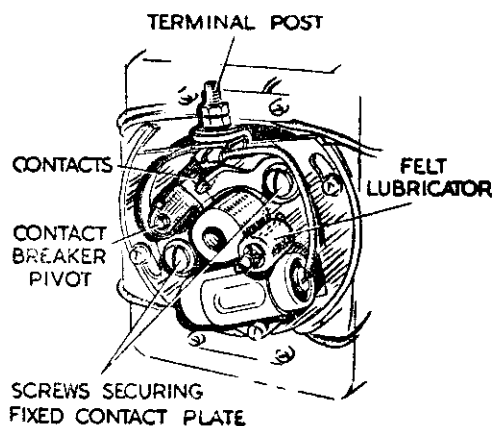

Fig. Y.41. Contact breaker.

The principle of operation of the induction alternator is the same as that of other generators, that is, the reversal of magnetic flux through the coil core which generates an EMF or voltage in the coil winding. In the normal generator, the reversal of flux is achieved by rotating either the magnet or coil, but in this design the coils and magnets are stationary and a laminated steel rotor is used to cause the flux reversals. The rotor is of 6-pole design in order to give as many flux reversals as practicable during one revolution.

Thus the windings are stationary, so avoiding the use of commutator, slip rings or collector brushes, making for greater robustness of construction and hence increased reliability.

The generator reaches its rated voltage at a low engine speed and the voltage is then maintained within close limits over a very wide speed range.

#### Coil Ignition—and Easy Starting with a Flat Battery

In addition to supplying the current required by the lamps (which, incidentally, have an increased headlamp bulb wattage of 30, with consequently greater light output than hitherto), the 1A45 unit also supplies power for the coil ignition equipment. The long standing objection to coil ignition on motor cycles, namely inability to start if the battery is run down, is overcome by providing 'emergency start' switching for use on these occasions. By means of this arrangement the battery is temporarily disconnected so that all the available energy from the permanent magnet alternator is applied to the coil, with the result that a slow speed performance approaching that of a magneto enables a 'kick-start' to be achieved. Thus the simplicity and economic benefits of this form of ignition can be utilised to the full.

## **Battery Charging**

Since batteries can be charged only by direct current, a Selenium metal rectifier is incorporated in the system, and all components then run off direct current from the battery source. Two plates are used in the rectifier assembly to provide full-wave rectification in conjunction with the centre-tapped generator. The rating of the rectifier plates has been thoroughly investigated both in temperate climates, and in the high ambient temperatures of the Middle East. The rectifier is of robust construction and is sealed against water ingress, making it suitable for mounting in a semi-exposed position where it will receive adequate air cooling.

With this equipment there is no need to fit a cut-out as the reverse current through the rectifier is very small, and is a negligible drain on the battery. To avoid even this slight drain, which is very little more than the usual surface discharge across the top of the battery, the ignition switch is arranged to disconnect the battery and alternator when the ignition is switched off.

The ignition switch has three positions: 'Off', 'Emergency Start', and 'Normal Start'. 'Emergency Start' position enables the engine to be started and run with a flat battery.

The alternator has an ample margin of safety but should not be run with the battery removed and/or the ignition switch in the emergency position any longer than is necessary.

**NOTE:— SWITCH OFF THE 'HEAD' AND 'PILOT' LAMPS BEFORE STARTING THE ENGINE WITH THE IGNITION. SWITCH IN THE 'EMERGENCY START' POSITION. FAILURE TO OBSERVE THIS PRECAUTION MAY RESULT IN BLOWN HEADLAMP BULBS.**

**IMMEDIATELY THE ENGINE IS RUNNING TURN THE IGNITION SWITCH SMARTLY BACK TO THE NORMAL RUNNING POSITION THEN SWITCH ON THE 'HEAD' OR 'PILOT' LAMPS AS REQUIRED.**

## **Two Charging Rates**

Reduced charge switching is coupled to the lighting switch so that full output is obtained from the generator only when the lamps are switched on, whilst during day running, a reduced charge resistance is inserted into the circuit.

Since the excitation is by means of permanent magnets, the wattage output for a given speed is limited and a higher battery voltage results in a decrease of charging current rather than an increase, so that the system is to a certain extent self-regulating.

The lighting switch is similar to the standard Lucas U.39 motor cycle lighting switch and provides positions for 'Lights off—Half charge', 'Pilot and Tail lights and Full charge', and 'Head and Tail lights with Full charge'.

## **Performance Data**

Output 7—10 amperes. Half-charge rate 5 amperes. (With coil ignition the battery will be charged at the rate of 3 amperes when running normally with lights off). Alternator will commence to charge the battery at 600 engine revolutions per minute. Maximum output is attained at approximately 2,000 r.p.m. and is substantially maintained to maximum engine revolution.

## **Running Maintenance**

Maintenance is restricted to occasional inspection and lubrication of the contact-breaker parts, and normal routine attention to the battery. No adjustment is necessary (or possible) to either alternator or rectifier. Every 1,000 miles (or monthly, whichever is the lesser period) remove the contact-breaker inspection cover for inspection of the contact points.

## B.S.A. Service Sheet No. 812 (continued)

The contacts must be free from grease or oil. If they are burned or blackened, clean them with a fine carborundum stone or very fine emery cloth, afterwards wiping away any trace of dirt or metal dust with a petrol-moistened cloth. Reset contact-points to .010 — .012 ins. A few drops of good quality engine oil should be applied to the cam lubricating wick if it is dry. Place a small amount of Mobil grease No. 2 or clean engine oil on the contact-breaker pivot.

If the alternator requires any attention beyond the replacement of contact points and condenser, it is recommended that the complete machine should be sent to an authorised Lucas service station. The following information is given for the benefit of those unable to do so:

### **SERVICE INSTRUCTIONS,**

#### **Removal of Alternator**

Remove alternator cover. Disconnect all wires at the 'Snap' connectors under the front of the petrol tank. Remove rotor retaining bolt. Insert special rotor extracting bolt supplied with machine and withdraw the rotor until it is just free of the crankshaft. Remove the nuts and spring washer from the through-studs securing the alternator body to the crankcase and lift the complete alternator bodily from the machine.

#### **Important**

THE ROTOR SHOULD ON NO ACCOUNT BE REMOVED FROM THE ALTERNATOR BODY. IF THE ROTOR IS WITHDRAWN IT WILL BE NECESSARY TO RETURN THE COMPLETE ALTERNATOR TO THE MAKERS FOR RE-ASSEMBLY AND RE-MAGNETIZING.

#### **Stator Coil Removal**

Disconnect the four leads from the terminal plate by unsoldering the terminals. Remove the two coil clamp fixing screws at the top and bottom of each coil. Remove clamps. Remove the insulation from the front of the body and the complete coil assembly can be lifted away from the alternator.

#### **Contact-Breaker Removal**

Unscrew the contact-breaker base fixing screws, then lift up the contact plate complete with the condenser. The position of the contact-breaker base relative to the alternator body should be noted and marked to obviate the need for resetting the ignition timing on reassembly.

### **INSPECTION AND TEST**

#### **Stator Coils**

Replace coils if (a) the insulation is frayed or damaged, leads broken, or open-circuited windings (b) if the coil laminations are damaged and will not fit satisfactorily on to the Stator magnets. A preliminary test of the coil assembly should be made with an OHM-METER which should give a reading of 0.4 ohms. The two coils are not symmetrical and in the event of a fault in one coil, it will be necessary to replace the complete coil assembly consisting of the pair of coils.

During the re-fitting of coils, the laminations should be carefully inspected to make sure they are free of all traces of dirt, grease and especially any magnetically attracted particles such as swarf or filings.

#### **Rotor**

The rotor has no moving parts and is not subject to any wearing process. IT SHOULD NOT UNDER ANY CIRCUMSTANCES BE REMOVED FROM THE ALTERNATOR BODY or loss of magnetism will result. The alternator is designed in such a way as to prevent accidental removal of the rotor.

### Contact Breaker Assembly

Deal with the contact-points as advised in Maintenance Instructions. The condenser is of normal Lucas design with a capacity of .2 microfarads.

### Final Test and Assembly

Assembly of the unit should be carried out reversing the dismantling procedure. Refit the alternator to the engine as follows: Place the assembled alternator on the crank-case so that it locates on the register or spigot. Apply medium pressure to the rotor and rotate it until it registers with the driving key on the engine crankshaft. Insert the alternator body bolts and tighten down evenly.

The final test should be carried out as follows: Remake all connections. The engine should then be started up and run at medium speed—approximately 2,000 r.p.m. Use a moving iron or rectified type voltmeter and test the potential between G2 and G3. See Service Sheet No. 813. A reading of 17 — 18 volts should be obtained. Apply the same test between G1 and G3. A similar voltage reading should be obtained. A further test should be applied across the same terminals with a 6 volt 36 watt bulb, which should light up.

Switch off the ignition and remake all external wiring connections to the alternator in accordance with the Wiring Diagram. A further test should then be made with the rectified type voltmeter and a reading of approximately 20 volts should be obtained between terminals G1 and G2.

Finally when all leads are connected the headlamp should be switched on and the engine run at a speed sufficient to obtain maximum output. Taking into consideration the current consumed by headlamp, tail lamp and coil ignition, the total output of the generator should not exceed 10 amps. In the event of too high an output being given, it can be reduced by partially withdrawing the rotor from the alternator body. **THIS WILL BE NECESSARY ONLY IN EXTREMELY RARE CASES, AND UTMOST CARE MUST BE EXERCISED IN WITHDRAWING THE ROTOR. NOT MORE THAN A QUARTER OF THE ROTOR LAMINATIONS SHOULD BE ALLOWED TO PROTRUDE BEYOND THE ALTERNATOR MAGNETS.**

### General Precautions

The set is designed for POSITIVE EARTH connection only. If the battery is connected with negative to earth, the rectifier unit will be burnt out or at least badly damaged immediately the ignition is switched on. The alternator set has an ample margin of safety, but should not be run with the battery removed and/or the ignition switch in the emergency position any longer than is necessary. Prolonged operation under these conditions will result in the ignition coil overheating due to higher operating voltage in the primary circuit and will lead to a shorter life of contact-breaker points. In the event of mechanical damage to the rectifier, or damage due to the unit becoming burnt out through incorrect fitting of the battery, it will be necessary to fit a new rectifier. It is not possible to repair a damaged unit.

The new rectifier must be fitted to the machine in the manner and place specified by the makers, i.e. spacer bushes must be used to allow the air free access to both sides of the rectifier, and if the rectifier is fitted to the machine in an inverted position it must be replaced in a similar manner.

### Replacements

DESCRIPTION	NUMBER	
Headlamp (Main Bulb) .. .. .	309	30/30 Watt (Export)
Headlamp (Main Bulb) .. .. .	312	30/24 Watt (Home)
Tail Lamp .. .. .	200	3 Watt
Pilot Bulb .. .. .	988	3 Watt
Alternator 1A45 .. .. .	47077D	
Westalite Rectifier .. .. .	2L985	

B.S.A. MOTOR CYCLES LTD.  
Service Dept., Birmingham 11  
Printed in England.

# **BSA SERVICE SHEET No. 812A**

*Reprinted September 1959*

## **SUPPLEMENT TO SHEET No. 812.**

**Lucas Alternator Equipment on B.S.A. Bantam Motor Cycles.**

**Type IA45**

**Service Reference 47077D.**

---

The IA45 Alternator fitted to B.S.A. Bantam Motor Cycles is a development of the Standard Lucas design described in Service Sheet No. 812 and is specified for all Bantam machines fitted with Lucas equipment. A six-pole laminated rotating inductor and laminated stator coil assembly are used as in the standard machine but the modified unit now incorporates a roller steady bearing for the contact-breaker end of the rotating inductor, and the alternator body is secured to the engine with four fixing bolts.

### **WORKSHOP INSTRUCTIONS.**

Dismantling and re-assembly should be carried out as indicated in Service Sheet 812 but the following should be specially noted:—Provision is made for the easy removal and replacement of the steady bearing and bearing plate; the cam and steady bearing journal are both press fits on to the rotor shaft and can be removed by means of a suitable extractor of standard pattern. On re-assembly, it is imperative that the cam is correctly fitted in relation to the rotor shaft or the performance of the machine will be adversely affected when the engine is run with the ignition switch in the "emergency start" position.

The general procedure for re-fitting the Alternator to the motor cycle is the same as is given in Service Sheet 812 but the following precaution must be taken in order that the steady bearing is correctly aligned. During the re-fitting operation, the four contact plate fixing screws ("A" Fig. 42) should be slackened off and should not be re-tightened until the remainder of the re-fitting operations are completed, i.e., the Alternator fixing bolts and the rotor retaining bolt should be fully tightened before finally tightening the contact-plate fixing screws. The fixing screw holes in the contact plate are drilled oversize and providing the foregoing precautions are observed, the contact plate will automatically align the steady bearing with the rotor shaft.

The final test of the machine should be carried out as detailed in Service Sheet No. 812

IA45 INDUCTOR ALTERNATOR — Parts Details.

Alternator complete type IA45, clockwise rotation	...	47077D
Condenser	.....	465817
Contact Set	...	407050
Coils, Stator set of two	...	465713
Cam	...	465800
Support Plate for Steady Bearing	...	465816
Bearing RLS5E	...	189243
Sundry Parts Set	...	465784

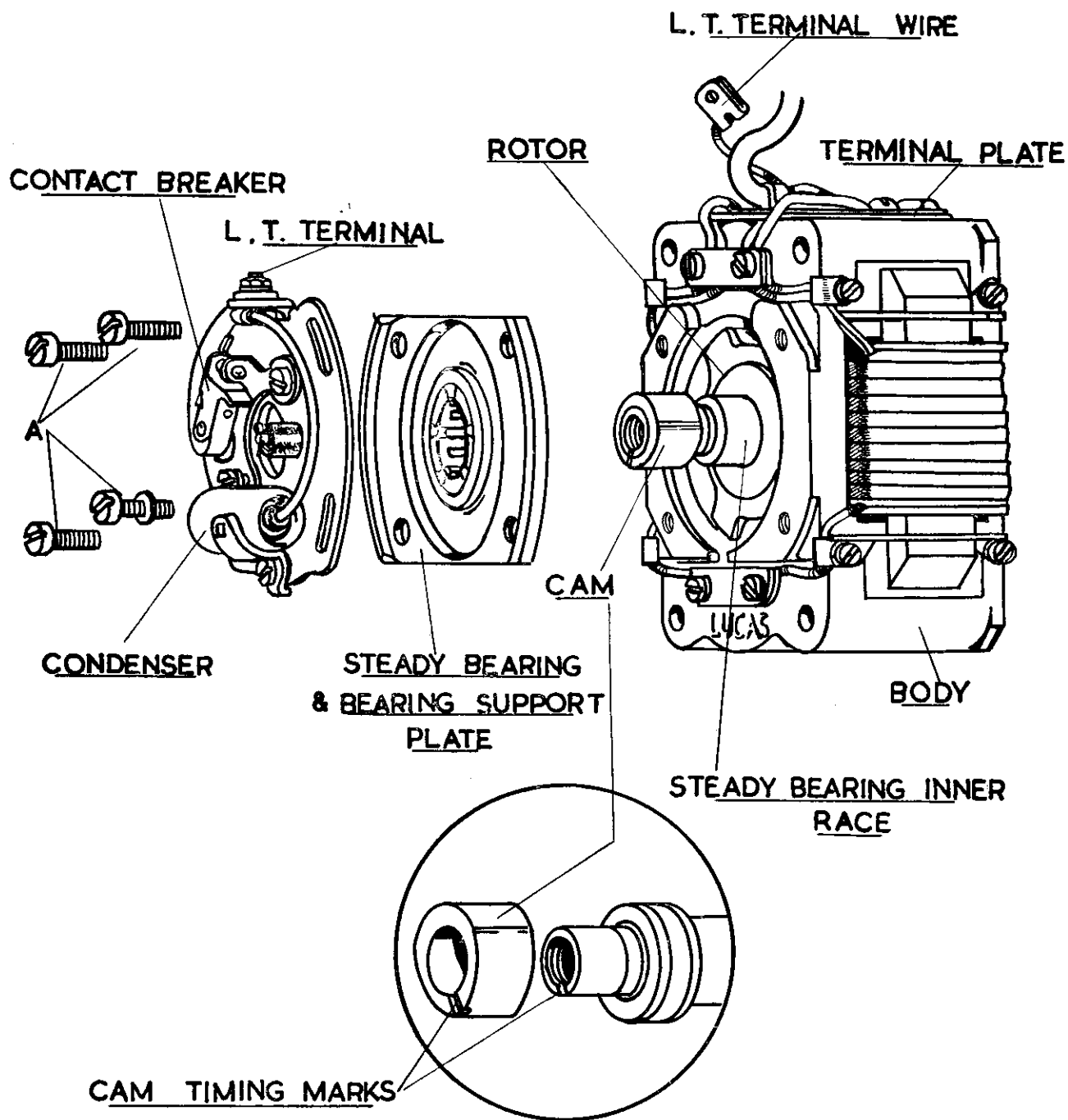
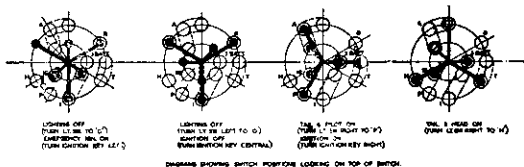

FIG. 42

**GENERAL ARRANGEMENT OF IA45 ALTERNATOR**  
SERVICE REF. No. 47077D FITTED TO B.S.A. BANTAM MOTOR CYCLES

WIRING DIAGRAM



KEY TO CABLE COLOURS

- 1 BLUE
- 2 BLUE with RED
- 3 BLUE with YELLOW
- 4 BLUE with WHITE
- 5 BLUE with GREEN
- 6 BLUE with PURPLE
- 7 BLUE with BROWN
- 8 BLUE with BLACK
- 9 WHITE
- 10 WHITE with RED
- 11 WHITE with YELLOW
- 12 WHITE with BLUE
- 13 WHITE with GREEN
- 14 WHITE with PURPLE
- 15 WHITE with BROWN
- 16 WHITE with BLACK
- 17 GREEN
- 18 GREEN with RED
- 19 GREEN with YELLOW
- 20 GREEN with BLUE
- 21 GREEN with WHITE
- 22 GREEN with PURPLE
- 23 GREEN with BROWN
- 24 GREEN with BLACK
- 25 YELLOW
- 26 YELLOW with RED
- 27 YELLOW with BLUE
- 28 YELLOW with WHITE
- 29 YELLOW with GREEN
- 30 YELLOW with PURPLE
- 31 YELLOW with BROWN
- 32 YELLOW with BLACK
- 33 BROWN
- 34 BROWN with RED
- 35 BROWN with YELLOW
- 36 BROWN with BLUE
- 37 BROWN with WHITE
- 38 BROWN with GREEN
- 39 BROWN with PURPLE
- 40 BROWN with BLACK
- 41 RED
- 42 RED with YELLOW
- 43 RED with BLUE
- 44 RED with WHITE
- 45 RED with GREEN
- 46 RED with PURPLE
- 47 RED with BROWN
- 48 RED with BLACK
- 49 PURPLE
- 50 PURPLE with RED
- 51 PURPLE with YELLOW
- 52 PURPLE with BLUE
- 53 PURPLE with WHITE
- 54 PURPLE with GREEN
- 55 PURPLE with BROWN
- 56 PURPLE with BLACK
- 57 BLACK
- 58 BLACK with RED
- 59 BLACK with YELLOW
- 60 BLACK with BLUE
- 61 BLACK with WHITE
- 62 BLACK with GREEN
- 63 BLACK with PURPLE
- 64 BLACK with BROWN

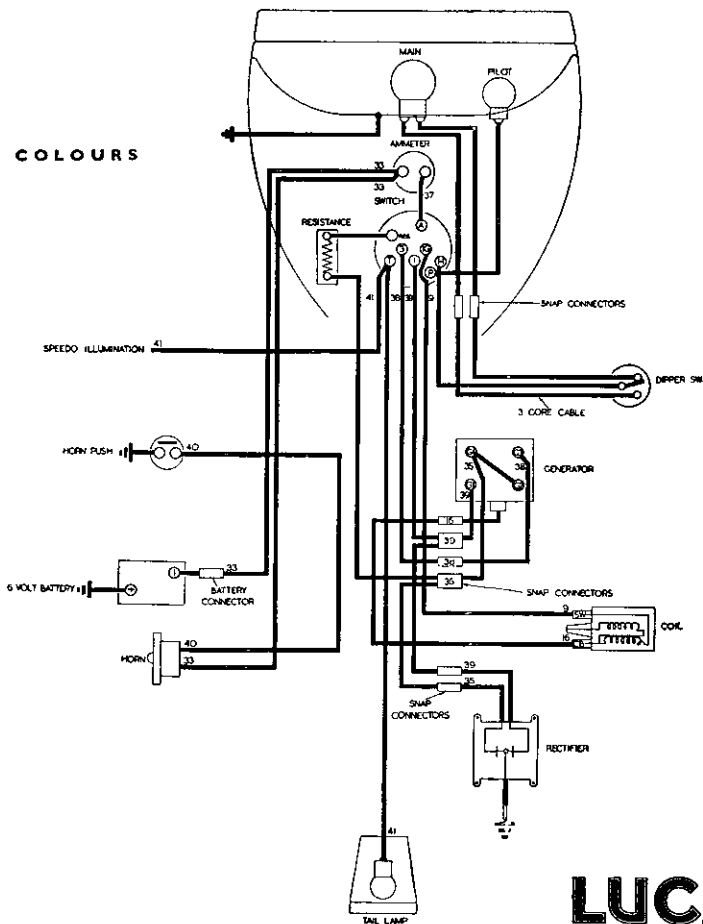

**LUCAS**  
ELECTRICAL EQUIPMENT

B.S.A. MOTOR CYCLES LIMITED.  
Service Dept., Waverley Works,  
Birmingham 10  
(PRINTED IN ENGLAND)